

Gjødseltrykker HTP 60

- Hydraulisk drift
- Trykker til platting eller kum
- Passer de fleste typer av gjøsel

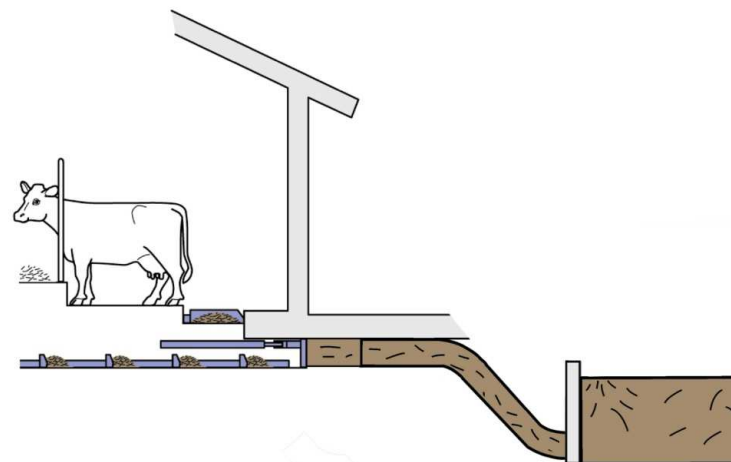
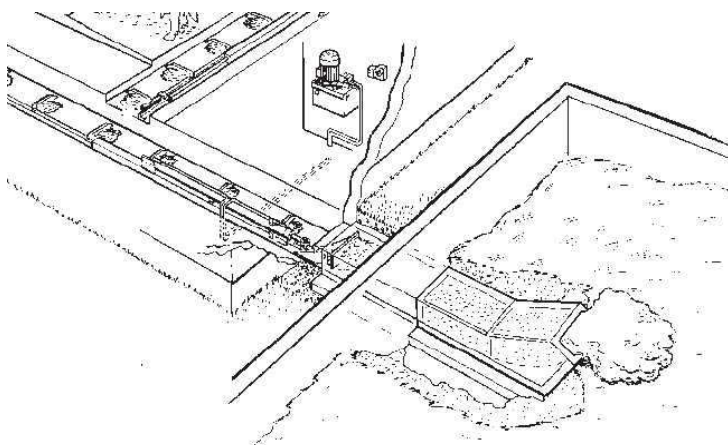

Gjødseltrykker HTP 60

- Effektiv og enkel borttransport av gjødsel
- Flytende og fast gjødsel
- Sterk pressklaff
- UNP 120 drivskinne
- Høyre- eller venstrefellende skraper
- Kan løfte opp til 5 m
- Kan transportere inntil 60 m fra presstrommel
- Robust konstruksjon



System HTP60 (Hydraulic Transfer Press 60)

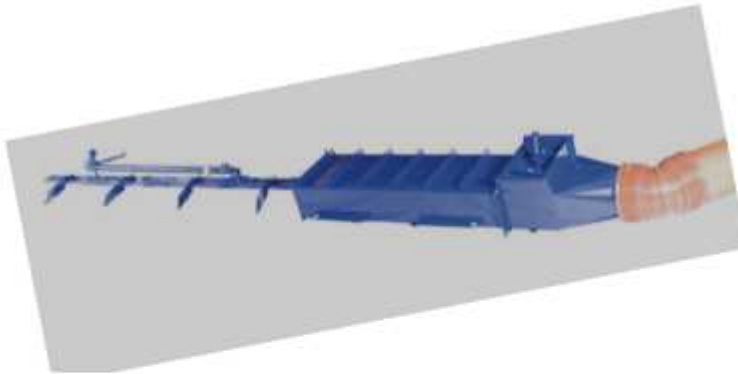

Kort beskrivelse av system

- Hydraulisk gjødseltrykker
- Godt utprøvd
- Håndterer alle gjødseltyper
- Stillegående pumpe
- 4.0 kW motor

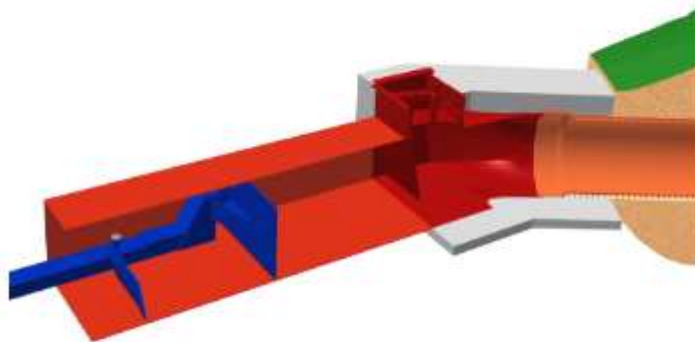

Bruksområde:

- Løsdrift og båsfjøs
 - Tverrenne for transport til permanent lager

System HTP60 (Hydraulic Transfer Press 60)



U120-profil

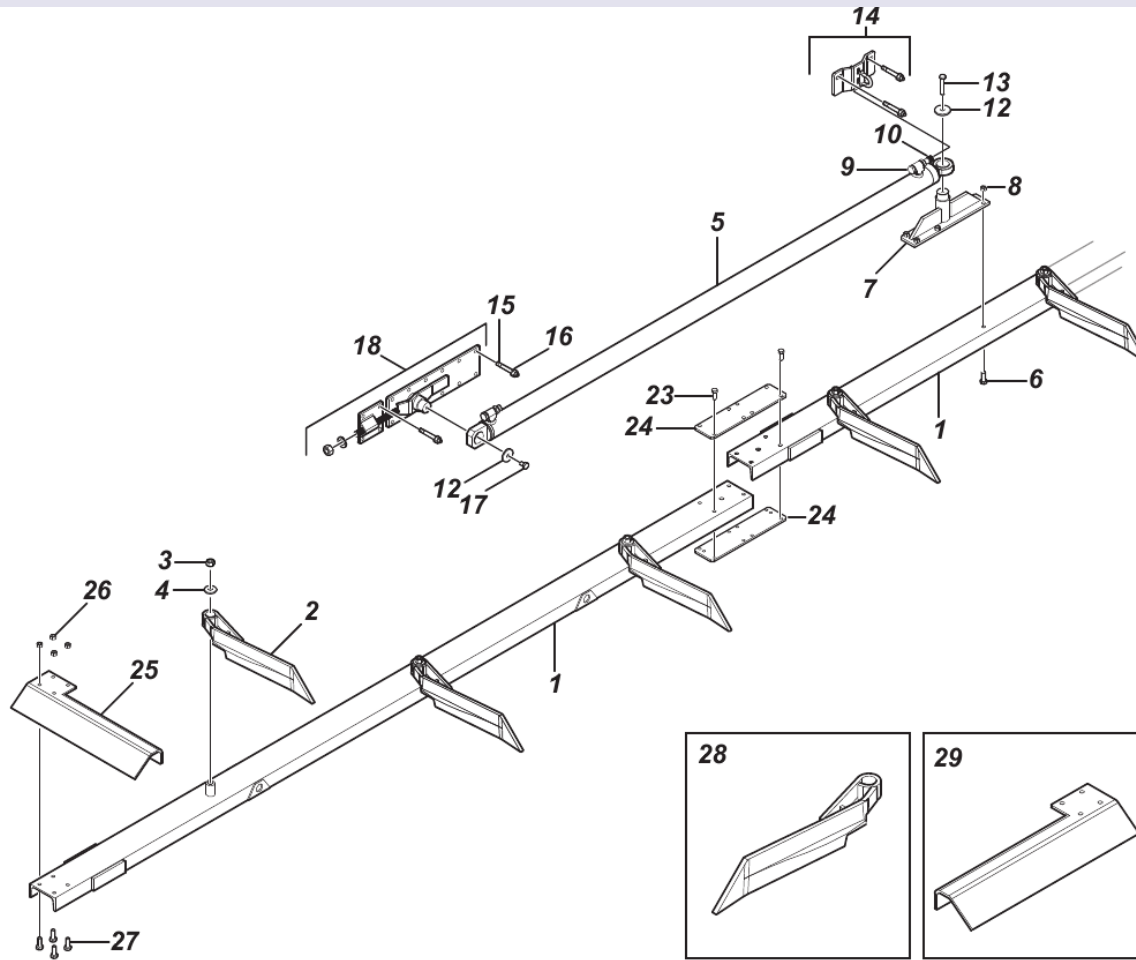

Internal

System HTP60 (Hydraulic Transfer Press 60)



Enkelt å skifte skraper

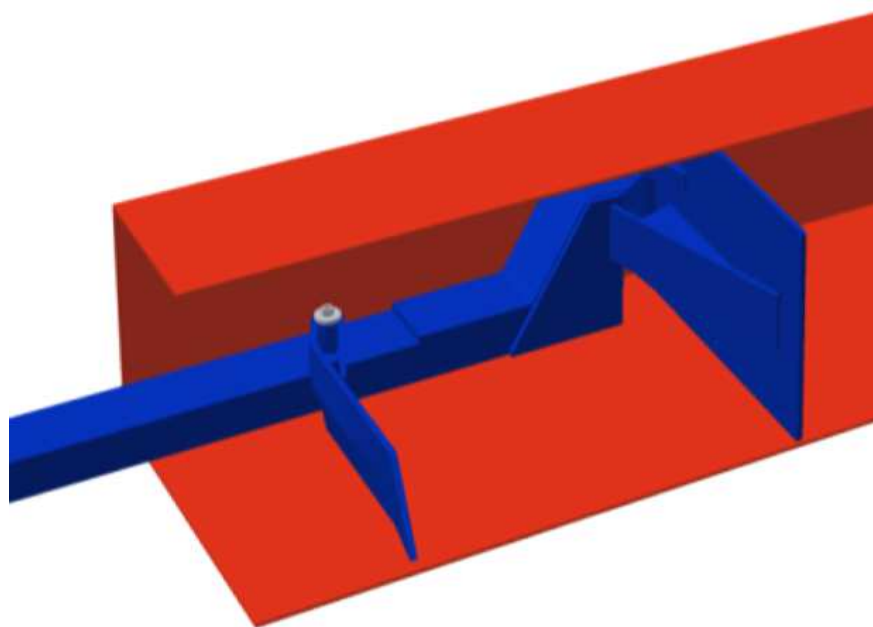

Gjødseltrykker HTP 60



Gjødseltrykker HTP 60

- Planlegging
 - Tverrenne i enden
 - Tverrenne på midten

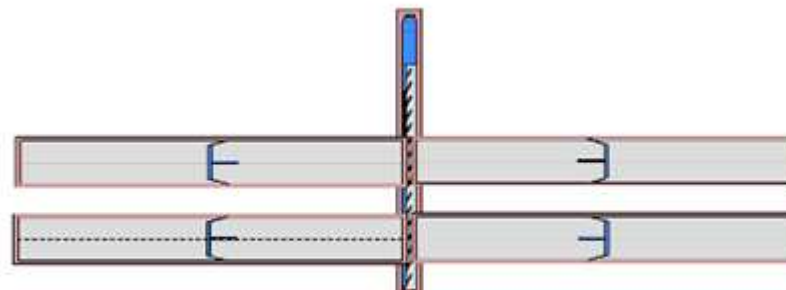
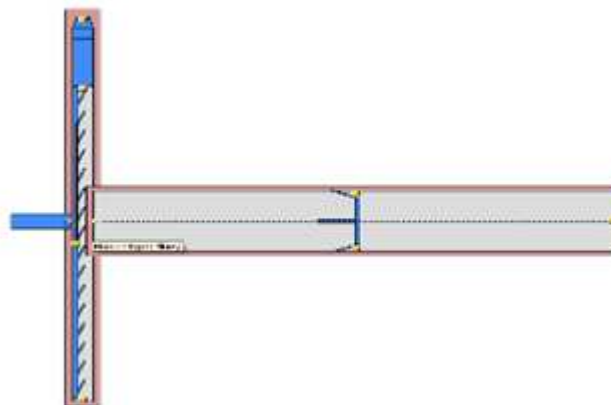

Gjødseltrykker HTP 60

- Hydraulikkpumpe
- Presstommel
- Skraper
- Sylinder
- Styreskap
 - BH1
 - BSC MCB
 - BSC

